

Warmup®

The world's best-selling electric floor heating brand™



Installation Manual: Snow Melting & De-Icing Mats and Cables for use under Asphalt, Concrete or Pavers



IMPORTANT

Read this manual before attempting to install your heating system. Incorrect installation could damage the heating system and will invalidate your warranty.

TECHNICAL HELPLINES
US: 1-888-927-6333
Canada: 1-888-592-7687

Table of Contents

Product Specification.....	2	Installation - under Concrete.....	8-9
Construction of Snow Melt Systems.....	2	Installation - under Pavers.....	10
Sizing Guides.....	2	How to Modify the Mat.....	11
Before Installation.....	3	Installation of loose cables.....	12
Control of Snow Melt System.....	4	Connection Diagram.....	13
Electrical Provisioning.....	5-6	Draw Your Plan.....	14
Installation - under Asphalt.....	7	Warranty & Exclusions.....	15

PRODUCT SPECIFICATION AND DETAILS

Snow Melting Mats/Cables are uniquely designed for snow melting in parking lots, driveways, pavements, stairs, bridges, roofs, etc. with total safety. Snow melting systems are heating cables taped to a sturdy mesh for fast, easy installation.

Snow Melting Mats and Cables consist of a twin conductor heating cable taped onto the Polypropylene mat. The heating cable is laid in a winding fashion so that they are equally spaced (3" apart) and evenly distributed on the mat.

Type	Twin Conductor
Voltage	120V, 208V, 240V
Output	50W/sq ft (540W/sq m)
Element Sizes	6 to 120 sq ft
Lead	16' 4"
Bending Radius	Minimum 1-1/2"
Cable Diameter	1/4"
Wire Insulation	Fluoropolymer
Casing	Zero Halogen Polyolefin
Max Temperature	464°F / 240°C
Min Installation Temp	14°F / -10°C

CONSTRUCTION AND SELECTION OF SNOW MELTING MAT AND CABLE

The Heating Cable on the Snow Melting systems consists of a resistance-heating element insulated with Fluoropolymer and Polyolefin-based compound, having high dielectric strength and good temperature stability, which makes the heating cable totally safe. A metallic sheath is provided to give additional mechanical strength and provide ground path. A final outer jacket of Zero Halogen Polyolefin based compound is given to make it sturdier and provide corrosion protection. The heating cable consists of a cold lead as required. The hot and cold junction is uniquely designed to make it safe and easy.

Warmup Snow Melting Sizing Guide

	Area (ft ²)	Mats	Size (W X L)	Resistance (Ω)	Wattage (W)	Amps (A)
120 VOLT	6.0	WSMM-D-0300-120	2' x 3'	48.0	300	2.5
	10.0	WSMM-D-0500-120	2' x 5'	28.8	500	4.2
	20.0	WSMM-D-1000-120	2' x 10'	14.4	1000	8.3
	30.0	WSMM-D-1500-120	2' x 15'	9.6	1500	12.5
	40.0	WSMM-D-2000-120	2' x 20'	7.2	2000	16.7
	50.0	WSMM-D-2500-120	2' x 25'	5.8	2500	29.8
240 VOLT	6.0	WSMM-D-0300-240	2' x 3'	192.0	300	1.3
	10.0	WSMM-D-0500-240	2' x 5'	115.2	500	2.1
	20.0	WSMM-D-1000-240	2' x 10'	57.6	1000	4.2
	30.0	WSMM-D-1500-240	2' x 15'	38.4	1500	6.3
	40.0	WSMM-D-2000-240	2' x 20'	28.8	2000	8.3
	50.0	WSMM-D-2500-240	2' x 25'	23.0	2500	10.4
	100.0	WSMM-D-5000-240	2' x 50'	11.5	5000	20.8
	120.0	WSMM-D-6000-240	2' x 60'	9.6	6000	25.0

	Cables	Length (ft)	Resistance (Ω)	Wattage (W)	Amps (A)	Coverage at 3" spacing (sqft)	Coverage at 4" spacing (sqft)	Coverage at 5" spacing (sqft)
240 VOLT	WSM-D-240V-40W/1000	84	57.1	1000	4.2	20	27	34
	WSM-D-240V-40W/2000	168	28.9	2000	8.3	43	57	72
	WSM-D-240V-40W/2500	209	23.1	2500	10.4	51	67	84
	WSM-D-240V-40W/3000	251	19.2	3000	12.5	62	84	104
	WSM-D-240V-40W/4500	375	12.8	4500	18.8	90	123	150
	WSM-D-240V-40W/5000	420	11.5	5000	20.8	100	140	170
	WSM-D-240V-40W/5500	458	10.5	5500	22.9	110	155	190

IMPORTANT INSTRUCTIONS BEFORE INSTALLATION OF THE SYSTEM

Measure and plan the area to be heated with the snow melt mats/cables, allowing for obstructions such as lights, poles, columns, handrails or drains. For complete snow removal, select mats to cover the entire area.

1. The heating cable should not cross or overlap itself at any point. This could cause the cable to overheat, requiring replacement.
2. The heating cable should not be cut, shortened or lengthened.
3. The heating cable length should NOT be altered under any circumstances. This may cause overheating, resulting in damage to the cable.
4. Take precautions to avoid damage to the heating cable during installation. Do NOT drop sharp objects or drive on the cable. Take care when pouring concrete or asphalt onto the cable.
5. Installation of the snow melt mats and cables should not be undertaken if ambient temperature is below 14°F (-10°C).
6. Minimum bending radius of the heating cable while laying shall not be less than approximately 2 inches (50mm) or not less than 10 times its diameter.
7. The cold lead, normally 16'4" long (5m), can be cut/extended to suit the location of the electrical power connection box.
8. Snow/Moisture detection sensor location shall be in the open area, away from trees or bushes, so that it can sense moisture in the air/snowfall and initiate the energization of the heating cable.
9. Check the voltage and wattage of the heating cable to ensure you have the right products for your installation. Details are marked on the product box. A qualified electrician should connect the heating system.
10. Check the continuity and resistance of the snow melting mat before installing and also after installing. Resistance value should match the value shown in the Sizing Guide on the previous page. A tolerance of 5% to 10% is allowed.
11. Keep high voltage power wires in a separate conduit from the low voltage wire.
12. Snow Melting Mats/Cable should be connected to a GFEP protected breaker in the panel. Consult a qualified electrician.
13. Allow sufficient drying or curing period of the concrete/asphalt/sand after installing the snow melting mat / cable and before energizing the heating cable.
14. For easy reference, attach a label at the power distribution board indicating the location of the snow melting mats / cables installed.
15. All outdoor embedded installations must include the application of a nameplate provided by the manufacturer under NEC 426-13.

NOTE: The installation shall be in accordance with all enclosed instructions and in compliance with local and national electrical codes, namely part 426 of ANSI/NFPA, the NEC and CEC (Canadian Electrical Code), part 1 (re: GFCI, GFEP and RDC's).

WARNING!

The cable must NOT be shortened or cut in any manner or subjected to strain at the cable/splice point.

NEVER power up the heating cable prior to being buried in concrete, asphalt or in sand (even for testing purposes). This will prevent premature failure of the heating cable.

Connecting the cable to the mains should be undertaken only by an authorized electrician.

CONTROL OF SNOW MELTING SYSTEM

Your Warmup Snow Melting system should ideally be controlled by the approved and supported Warmup control devices. They can take the form of intelligent dual zone control panels, mounted indoors (ETO2 Panels), or simpler outdoor boxes with integrated sensors (DS-Series: DS2-DS5-DS8).

When using the DS-series, there are no ground or roof sensors to prepare for (except gutter sensor for DS8). When choosing the more integrated control panel (ETO2), carefully read the following sections when preparing for your sensor positioning.

RELAY CONTACTORS

Note the difference between a control panel and a relay contactor. A control panel effectively reads the information from the sensors and sends the required signals to the heating cable. Depending on the models available, they can be programmable and user-defined.

However, when using a large amount of heating cables (usually over 45Amps), Warmup will recommend the use of one or multiple contactor panels. The contactor panels will receive the connections from the heating cable leads, and subsequently be connected to the actual control devices. Call your Warmup representative with any questions.

INSTALLING SENSORS - CONDUITS AND FEEDER CABLE

When using the ETO2 controller and other indoor mounted options available from Warmup, you will have to install one or more ground and/or roof sensors. Ground and roof sensors can be combined on the same controller. The reason for installing multiple sensors is to gather faster or more diversified information to trigger your heating system, such as the north and south side of a building.

PLACEMENT OF SENSORS

One basic principle is to locate one sensor where the snow and ice will manifest first, and another where the snow is going to disappear last. This will guarantee complete clearing of snow and ice. For example, on a sloped down driveway to an underground garage, place a sensor at the top and at the bottom of the driveway. Remember a combination of sensors can be ground-ground or ground-roof.

When using only one sensor, you will have to choose between fast detection or the lasting melting period (place it where the snow will disappear last).

Ground sensors must be placed within the heated area. Ground sensors for the ETO2 panels detect moisture and temperature and should therefore be located halfway between the wires, anywhere within the heating area, and preferably 3 ft within the edges of the heated zone. Always maintain a minimum distance of 1" between the sensor conduits, sensors and the actual heating cable. Finally, never place two sensors within 3ft of each other.

Snow Sensor and Controller

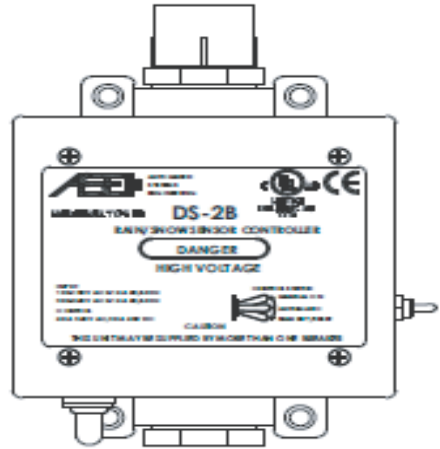

CONDUITS

After choosing the location of the sensors, you must install PVC or METAL conduits and ensure the connections are properly sealed. The mounting base for the ground sensor provides for it to be secured to a base (wood block, concrete block) in order to not push it down during or after the concrete pour.

Always ensure the conduits are secured to the base (rebar, drained gravel base, blocks) so that they do not move during the pour.

The conduits must route from the sensor location to the control panel. Check the specifications of the ground sensor you selected, and the length of its tail. You may need to install a feeder cable to extend the sensor to the panel.

NOTE: INSTALLATION IN ASPHALT

The temperature must not exceed 80 °C or 176 °F around the sensor and tube. Those temperatures are well below the typical asphalt pour temperatures, and we highly recommend the use of our reinforced cables specifically designed for asphalt. Always use METAL conduits for asphalt installations, and install your sensor retroactively. Create a wooden perimeter to protect your sensor location from the pour, and subsequently affix the sensor in the ground, finishing the pour around that section.

ELECTRICAL PROVISIONS

The heating system installation wiring shall be in accordance with the national Electric Code and any applicable local codes. Controls and accessories recommended for use along with the heating cables are listed below:

- Floor/Ground sensing temperature controller / thermostat
- Plastic or wire zip ties
- GFCI (Ground Fault Circuit Interrupter)
- Dedicated circuit breaker(s) for all heaters circuits

The location of the thermostat junction box shall be about 4' (1.2m) high from the ground for easy access. The sensor wire and the heating cable cold leads shall be routed to the thermostat/power connection box in separate conduits.

If the heating system has a load below 7,200W at 120V or 14,400W at 240V based on the thermostat power rating, it may be connected directly to an electronic thermostat as shown in the diagram below, and displays a typical scheme of the electrical system. If the heating system has a load of more than the thermostat power rating, contact Warmup on 1-888-927-6333.

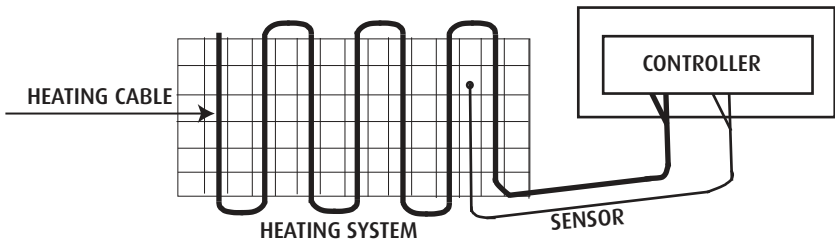

All electrical connections should be performed by a licensed electrician and be in compliance with the appropriate local and national codes.

Based on the amount of mats or cables purchased from Warmup, provide enough amperage supply to either control panel or the relay contactor. Check with your Warmup representative whether a contactor panel is used in your installation. Both are usually located next to each other, and mounted indoors.

Warmup's 24/7 Toll Free Technical Number: 1-888-927-6333

ELECTRICAL PROVISIONS (cont'd)

All circuits provided should be GFCI protected, however, some panels have a built-in GFEP protection. Check with your Warmup representative or refer to the specification sheet of the controllers purchased.

Make sure to supply the appropriate power to the controller or relay panels in order to operate the mats and cables. The voltages available are 120V, 208V and 240V. Make sure you understand the proper wiring if a 208V-3 phase connection is necessary or recommended by your general contractor as your amperage load requirements will change.

Note that the sensor wires can often be low voltage wires and should therefore ALWAYS be placed in their own, separate conduits. By the same token, while you may place multiple heating cable LEADS inside a single conduit, you should NEVER run the heating portion of the cable inside a PVC or METAL conduit.

All lead wires may be lengthened or shortened as necessary, but NEVER cut the HEATING CABLE. When extending the lead wires, we recommend the use of a wall-mounted or in-ground weather-proof junction box.

CABLE SPACING and HEATING OUTPUT

When using the pre-assembled Warmup Snow Melting mats, the standard cable spacing is approximately 3" and provides 50 watts of output per square foot.

When using a loose cable format, or when spacing the mats manually, note that the maximum recommended spacing for snow melting is 4", with an output of 37 watts per square foot. We do not recommend more than 5" and less than 2" for outdoor applications.

CABLE DE-RATING

It is possible and allowed to "de-rate" the power of a cable. In order to maintain the mats spaced as provided (3" spacing with 50w/sqft output), you can supply the 240V-rated mats with 208V power. ALWAYS CHECK WITH YOUR ELECTRICIAN and WARMUP REPRESENTATIVE for exact calculations.

De-rating the mats from 240V to 208V will bring a 50w output down to 37w/sqft. This technique is used to obtain more coverage with less amperage load.

MANUAL EXPANSION JOINTS (CONCRETE INSTALLATIONS)

When installing mats and cables in concrete slabs, carefully prepare for the potential incisions for expansion joints in the concrete.

Make sure the cable is not subjected to excess tension or strain. It should not cross an expansion joint. Where expansion joints are present, separate mats/cables should be used if possible.

As an alternative, mark the location of the expansion joints on the sub-base with chalk or spray-paint and use the following technique: Apply a 2" x 2" downward bend or loop in the cable. This will cause for that section of cable to be deeper, thereby avoiding the blades, as well as provide for some level of flexibility when the slab expands and contracts during the various seasons.

INSTALLATION INSTRUCTIONS - UNDER ASPHALT

We highly recommend the use of our reinforced cable specifically designed for asphalt use. When using the regular snow melt mats/cables under asphalt, consider embedding them in sand or concrete first.

Note: Using a megohmmeter and multi-meter, an electrician should measure the cable resistance and insulation resistance: (1) before commencing installation, (2) before applying asphalt and (3) after the asphalt is applied. Record the readings in this manual. If there is damage STOP and ring 1-888-927-6333.

1. Ensure the contractor has a firm base of 4"-8" (102-203mm) of concrete, sand or rock aggregate tamped down and ready to receive the asphalt.
2. Clean the area below the heating mat/cable so that it is free from sharp objects. It is extremely important to keep heavy equipment, machinery, vehicles, shovels and rakes away from the cable to prevent damage. In the application of asphalt, we recommend a maximum load of 2 tons for the roller. To minimize strain on the cable, lay the mats perpendicular to the roller's path.
3. Lay down the binder/base coat of asphalt and roller it smooth. The paving installer must decide if the binder coat of asphalt is allowed to cool before proceeding.
4. Unroll the mat or place the cable on the prepared surface (wires facing down, mesh-side facing up to help protect the wire) according to your layout plan and apply a coat of bituminous binder. See pg 10 "How to Modify the Mat" if you need to alter the mats (**Note: test the mats/cables to ensure they have not been damaged and record the readings**).
5. Once the mats/cables are in place, route the cold lead(s) provided through a rigid metal conduit to return to an accessible weatherproof junction box(es). The electrician may supply junction boxes which can be accessed from above so the rest of the box is buried to avoid damage by vehicles or lawn movers. [**Note: ensure none of the heated section of the cable enters the conduit(s)**]. Seal the ends of the conduit.
6. Sensors can be placed within the asphalted area. Refer to earlier sections under PLACING GROUND SENSORS on page 3.
7. When the mat/cable is embedded in sand or mortar, the asphalt should not exceed a thickness of more than 1.5" for optimal results. When pouring asphalt DIRECTLY on the mat/cable, let it cool to 230F and below. Again, use a maximum of 2" of asphalt for optimal results.
8. After the asphalt hardens, **test and record results** to verify that there is no damage and to ensure it is ready for activation once the asphalt has cured.
9. For easy reference, attach a label at the power distribution board, indicating the location of the heating cables.

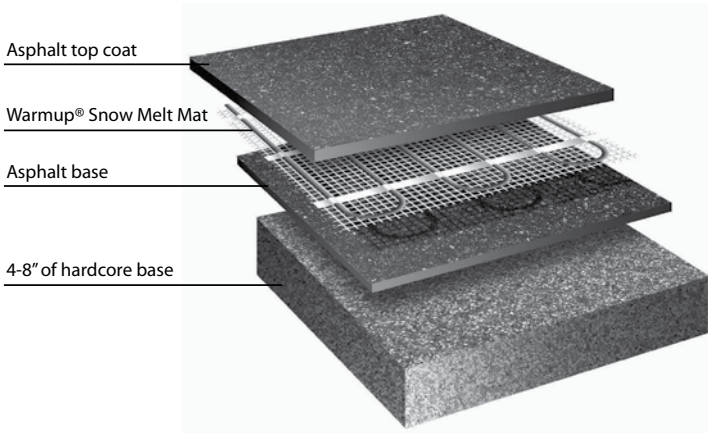

INSTALLATION INSTRUCTIONS UNDER CONCRETE

Note: Using a multi-meter, an electrician should measure the cable resistance and insulation resistance: (1) before commencing installation, (2) before pouring concrete and (3) after the concrete is poured. Record the readings. If there is damage STOP and ring 1-888-927-6333.

1. Ensure the paving contractor has a solid base of 4"-8" (102-203mm) of crushed rock aggregate tamped down and ready to receive the pour.
2. Clean the area below the heating mat/cable so that it is free from sharp objects. It is extremely important to keep heavy equipment, machinery, vehicles, sharp shovel and rake edges away from the cable to prevent damage.
3. For locations that require handrails, it is strongly recommended that the concrete installer pre-sleeves the posts to avoid any and all drilling of the concrete. The mat/cable must be routed around these sleeves/posts to avoid any direct contact with them. See pg 10 "How To Modify the Mat" if you need to alter the mats. The mat/cable must NOT pass through expansion joint locations. Avoid saw-cutting or drilling through cables that are no longer visible beneath the concrete by spray painting lines to mark exactly where expansion joints are located.
4. Place the mat or cable down on top of the tamped aggregate with the mesh facing up. Stake the mesh or cable firmly into the crushed rock so that it remains flat. (Note: **test the mats/cables to ensure they have not been damaged and record the readings.**)
5. Route the cold lead(s) through rigid PVC or metal conduit(s) to an accessible weatherproof junction box(es). Ensure that none of the heated section enters any conduit. Do not use excess force to pull the cold leads otherwise it may damage the hot-cold splice. Seal the conduit ends.
6. A ground sensor can be placed outside the paved area. When placed within the paved area (recommended), ensure proper measuring and securing for the base of the sensor itself as it shouldn't be flushed with the final coat of concrete. The sensor can be mounted on a wood or concrete block.
7. A separate conduit should be used to protect the low voltage sensor wire and must NOT be shared with any high voltage cold lead from the mats/cables.
8. Once the conduits & sensor(s) are in place, the sand can be poured, covering the mats/cables completely without leaving any air pockets, so that the cables are covered by 1.5" (38mm) of sand but not more than 2" (51mm).
9. An electrician MUST complete the final **test and record** results of all the mats/cables readings with a multi-meter and megohmmeter and verify that each mat/cable is in good working order and is ready for energizing once the sand has cured.
10. For easy reference, tape your plan [pg 13] to a power distribution board, indicating the location of the heating cables.

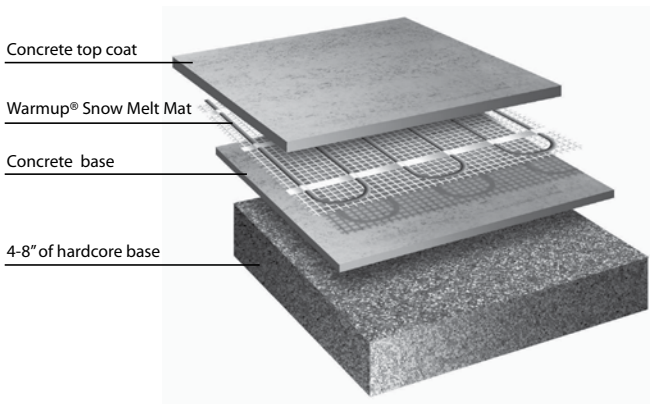

INSTALLATION INSTRUCTIONS UNDER CONCRETE (continued)

FOR SINGLE POUR INSTALLATION

1. Using a wire mesh or rebar, attach the snow melt mats/cables with plastic zip ties using 3"-4" (51mm-76mm).
2. Then prop up the rebar/mesh with either concrete rubble or brick pavers to the appropriate depth so that the heating mat/cable ends up 2"-3" (51mm-76mm) from the finished surface and no deeper. Make sure the mesh-side is facing up, to protect the cable from shovels and rakes.
3. Once the rebar/mesh/snow melting mat/cable is propped up, route the cold lead(s) through rigid metal or PVC conduit(s) to an accessible weatherproof junction box(es). Ensure that none of the heated section enters any conduit. Do not use excess force to pull the cold leads otherwise it may damage the hot-cold splice. Seal the conduit ends.
4. A separate conduit should be used to protect the low voltage sensor wire and must NOT be shared with any high voltage cold lead from the mat cables.
5. Once the conduits & sensor(s) are in place, the cement can be poured, covering the mats/cables completely without leaving any air pockets. The concrete should have a minimum thickness of 2" (50mm) measured from the top of the snow melting mat/cable.
6. An electrician MUST complete the final test and record results of all the mat/cable readings with a multi-meter and megohmmeter and verify that each mat is in good working order and is ready for energizing once the sand has cured.
7. For easy reference, tape your plan [pg 13] to a power distribution board, indicating the location of the heating cables.

INSTALLATION INSTRUCTIONS UNDER PAVERS

Note: Using a megohmmeter and multi-meter, an electrician should measure the cable resistance and insulation resistance: (1) before pouring sand and (2) after the sand is poured. Record the readings. If there is damage STOP and call 1-888-927-6333.

1. Ensure the paving contractor has a solid base of 4"-8" (102-203mm) of crushed rock aggregate tamped down and ready to receive the mortar pour or sand/gravel base.
2. Take extreme care to ensure the paver installer does NOT use any heavy equipment, machinery or vehicles over the exposed heating cables. We highly recommend the cable resistance be checked with a multimeter during the paving process by a qualified electrician. This will ensure detection of any unlikely faults as early as possible.
3. For installation on stairs and ramps that will include hand rails, it is strongly recommended that the paver installer pre-sleeves the posts to avoid any and all drilling of the mortar. The heating mat/cable must be routed around these sleeves or posts to avoid any direct contact with them. When preparing for railings, expansion joints and related, please ensure the contractor has clearly marked and informed the paving/concrete contractor of the cable location.
4. When laying the cables directly over a sand or gravel base, use landscape staples or provided cable strips to secure the mats and cables. Apply a second layer of gravel or sand of approximately 1" over the cables to ensure easy positioning of the pavers.
5. Route the cold lead(s) through metal or PVC conduit(s) to an accessible weatherproof junction box(es). The electrician must ensure that none of the heated section enters any conduit. For this type of application, we recommend the use of the DS series aerial sensors to avoid cuts in pavers and stone. When using in-ground sensors with the ET02 controller, please make sure to plan ahead for correct placement of sensors within the stone. (Note: **test the mats/cables to ensure they have not been damaged and record the readings.**)
6. Do NOT walk on the hot-cold factory splice and avoid damaging the mats/cables with shovels or rakes.
7. The electrician needs to complete the final testing of all the snow melting mats/cables with a multi-meter to verify and record that each heating cable is still operational after the pour of mortar and cured. Record these values at the back of this manual.

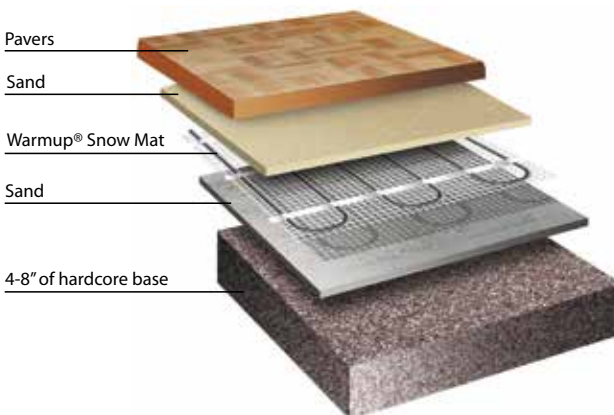

HOW TO MODIFY THE SNOW MELT MAT

Mats can be cut, turned and flipped to fit a specific area. **NEVER CUT THE CABLE.**

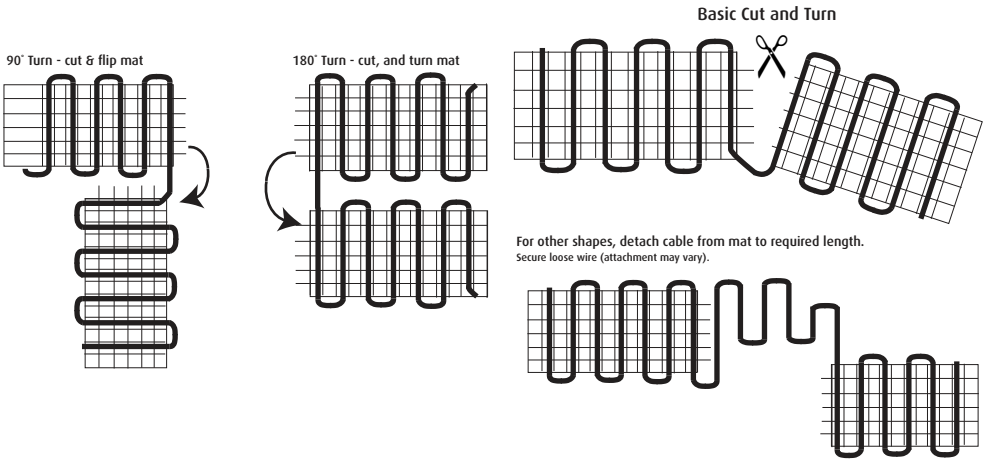

TESTING THE SNOW MELT MAT/CABLE

A. Insulation Resistance (megohmmeter required)

1. Connect one meter clamp to the cold lead inner conductor and the other meter clamp to the metal cable braided sheath (ground) of the heating cable.
2. Test in accordance with the meter manufacturer's instructions (recommended meter is a 500 VDC megohmmeter).
3. Megohmmeter reading should read greater than 10 megohms.
4. Ensure you test and record readings BEFORE, DURING and AFTER installation.

B. Total Cable Resistance (Multi-meter required)

1. Connect one meter clamp to one cold lead inner conductor and the other meter clamp to the other cold lead inner conductor.
2. Test in accordance with the meter manufacturer's instructions and record this Ohm value.
3. Total nominal cable resistance information is found in the Sizing Guide on page 1. Actual readings should be within 10% of the cable resistance.
4. Perform this test and record measured values on the Warranty Card BEFORE, DURING and AFTER installation.

If you are NOT getting accurate readings, STOP and call Warmup's 24/7 Technical Helpline on 1-888-927-6333.

INSTALLATION OF LOOSE CABLES

While the WARMUP WSMM mats come in pre-formed rolls with the cable pre-spaced at 3" for an optimum 50 watts/sqft output, the WSMC cables allow for custom spacing and installation on steps.

There are 2 methods to secure the cable:

- Attached to re-bar mesh or similar
- Secured to WARMUP CLIP system

When a reinforcement mesh like re-bar is used, apply the cables to the grid using zip ties. Do not use metal clamps or specific drills using metal wire twists. When spacing the cables, use the provided chart in this manual to define the total square foot output based on a 3", 4" or 5" spacing. Do not space the cables closer than 3" or wider than 5".

Another method to secure the cable and maintain consistent spacing is with the use of the WARMUP CLIP system. The clips come in strips of 3ft and provide adequate grooves to snap the cable. The clips can simply be laid down on the base (crushed gravel, sand, concrete) and if necessary, can be secured with hot glue or liquid nails. It is our experience that the weight of the cable tends to hold the clips down, although it is safer to secure the outer clips to prevent the system from shifting around when pouring concrete or laying pavers. Use the clips at both ends of the installation, and about every 3 to 5ft in between to ensure the cable is consistently spaced.

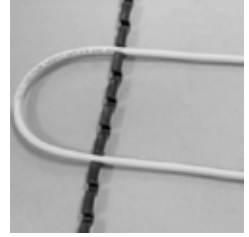

Warmup CLIP system

INSTALLATION OF LOOSE CABLES ON STEPS

The WARMUP Loose Cables are specifically designed to be applied on steps and landings. Here's how we recommend to proceed, using all the above-mentioned cautions and techniques.

1. We highly recommend the use of the WARMUP CLIP system. Cut the strips to about 10" or the depth of the steps and apply every 2 or 3ft in width to maintain consistent spacing of the cables.

2. On a 10" deep step, use 3 runs of the loose cable, ensuring that one of the runs is at the outer-most edge of the step. This is to guarantee that the heating will perform even when stones are laid with an overhang on the step. For any unusual layouts or masonry work, please contact WARMUP.

3. Start your work closest to the 1" conduit provided to route the lead wire. This can be at the top of the landing or at the bottom of the steps. Work your way up or down from there.

4. When transitioning to the next step, manually apply a 90 degree bend to the cable, gently fighting the cable memory. Do not over-bend the cable. Going up or down to the next step, use a slightly diagonal route to reduce the bending radius to a minimum and when possible, lightly chisel the sharp edges of a concrete stair base.

5. Note whether the drawings will call for the installation of railings. If so, and because railings are drilled after the masonry or concrete work, leave a minimum of 6" on the edges of the steps.

6. Even when making use of the WARMUP CLIP system, we recommend the punctual application of hot glue with a hot glue gun to secure some of the manual bending and laying of the cable and clips.

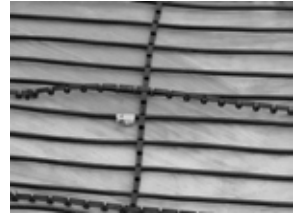

CONNECTION DIAGRAM

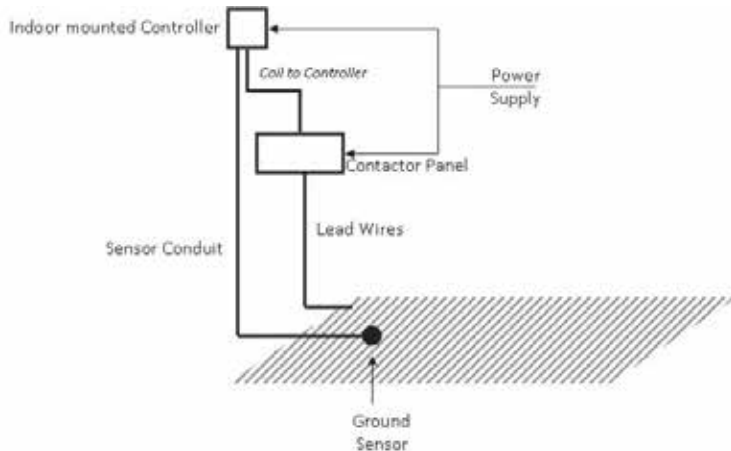
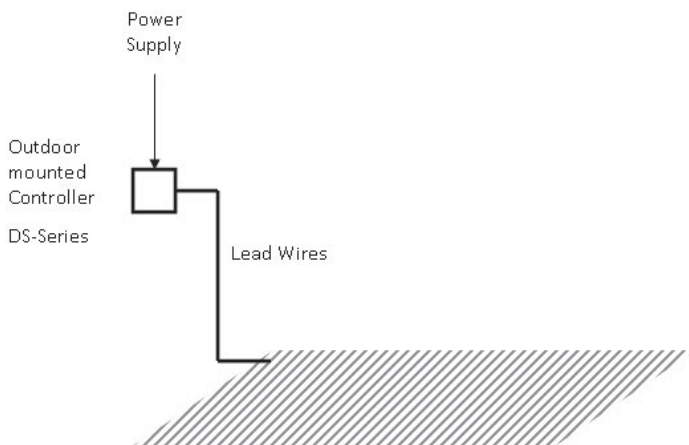
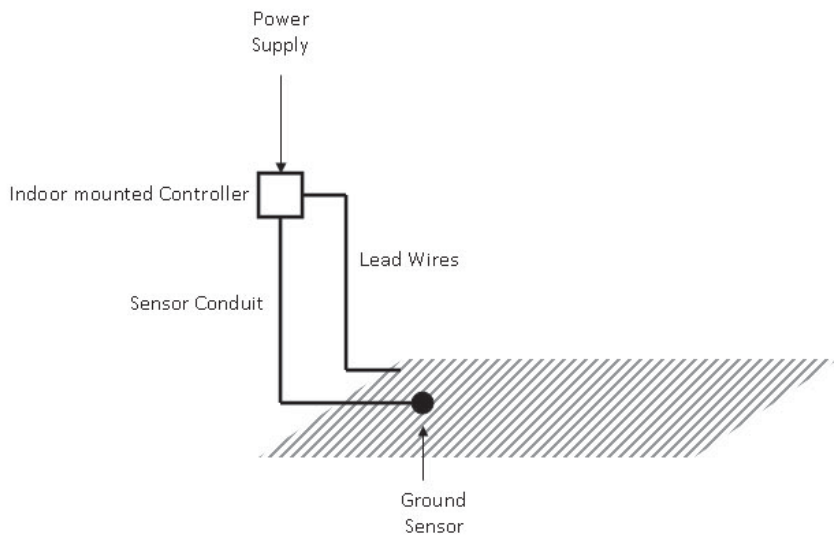

PLANNING YOUR LAYOUT

Draw a plan showing the layout and location of the snow melting mats/cables in the space provided.

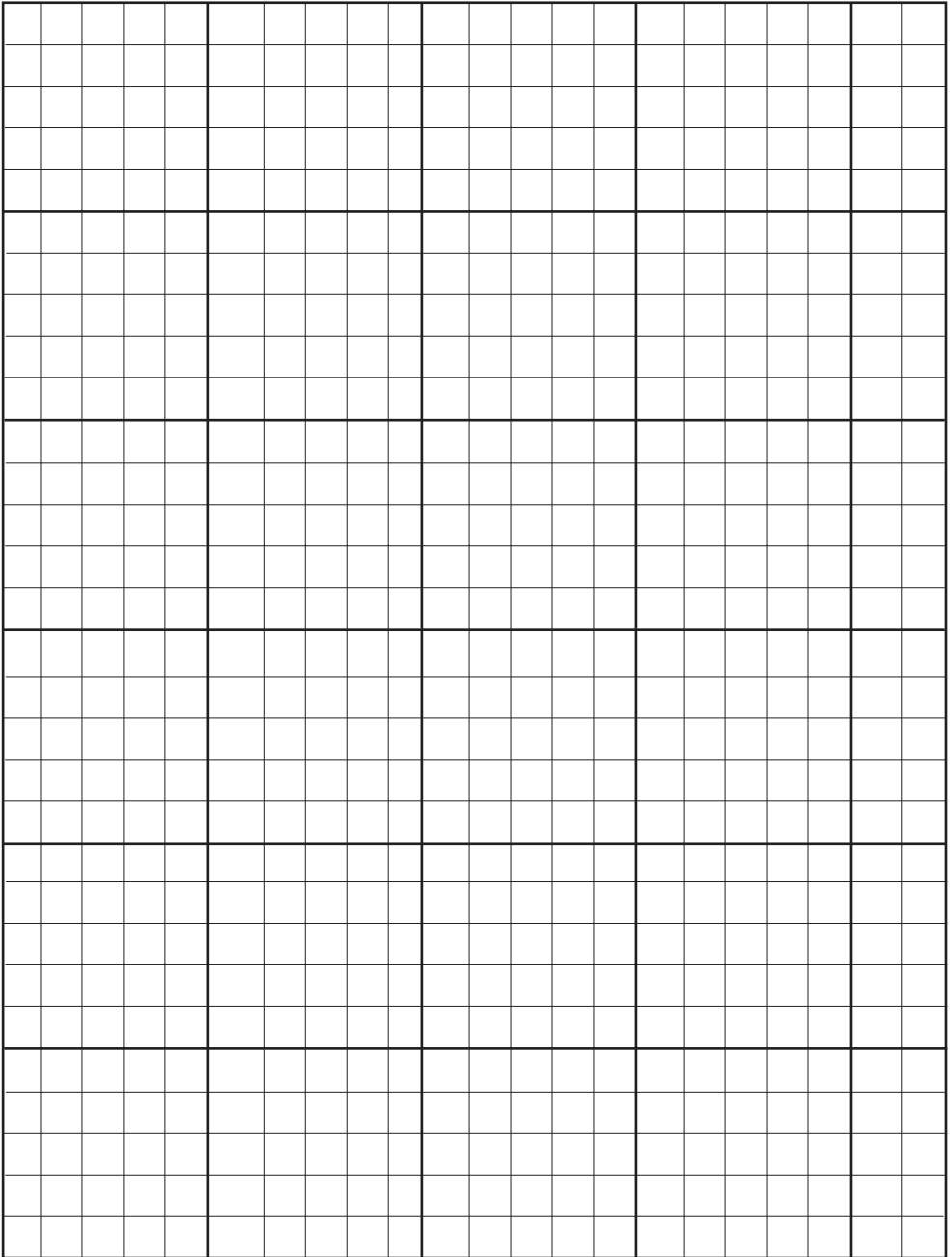



WARRANTY - Snow Melting Mats and Cables

Warmup provides a 10-Year Warranty (from date of purchase) for the Snow Melting Mats and Cables for the material and workmanship under normal operating conditions.

In case of defective material, Warmup's obligation will be limited to the repair or supply of new material, free of charge to the customer.

The Warranty does NOT cover installations made by unqualified personal or faults caused by incorrect design by others; misuse; damage caused by others; damage in transit; incorrect installation and any other subsequent damage that may occur. Cost related to repair/replacement will be fully chargeable to the customer if the damage is due to any of the above reasons.

Warmup is under no circumstances liable for consequential damages or losses including without limitations the loss or profit arising from any cause whatsoever. The guarantee is a material warranty only and does NOT cover field labor. **A qualified electrician MUST connect the heating system.**

The Warranty is void if there is any payment default and if data is not filled in correctly.

EXCLUSIONS

Warmup, Inc. shall in no event be liable for incidental or consequential damages, including but not limited to extra utility expenses or damages to property. This Warranty is null and void if:

- 1) The covering over the heater(s) is damaged, lifted, replaced, drilled into or repaired.
- 2) The heater fails due to damage caused during installation, unless damage is caused directly by an employee of Warmup. It is therefore essential to check that the heater is working (as specified in the installation manual) prior and during installation.
- 3) Damage as a result of floods, fires, winds, lightning, accidents, corrosive atmosphere or other conditions beyond the control of Warmup, Inc.
- 4) Use of components or accessories is not compatible with Warmup heaters.
- 5) Warmup products are installed outside the United States.
- 6) Parts not supplied or designated by Warmup, Inc.
- 7) Damage or repair required as a result of any improper use, maintenance, operation or servicing.
- 8) Failure to start due to interruption and/or inadequate electrical service.
- 9) Any damage caused by frozen or broken pipes in the event of equipment failure.
- 10) Changes in the appearance of the product that does not affect its performance.
- 11) The owner, or his/her designated representative, attempts to repair the product without receiving prior authorization from Warmup. Upon notification of a repair problem, Warmup, Inc. will issue an Authorization to Proceed under the terms of this Warranty. If Warmup is required to inspect or repair any defects caused by any exclusions referenced above, all work will be fully chargeable at Warmup's inspection and repair rates then in effect.

WARMUP, INC. DISCLAIMS ANY WARRANTY NOT PROVIDED HEREIN, INCLUDED ANY IMPLIED WARRANTY OF THE MERCHANTABILITY OR IMPLIED WARRANTY OF FITNESS FOR A PARTICULAR PURPOSE. WARMUP, INC. FURTHER DISCLAIMS ANY RESPONSIBILITY FOR SPECIAL, INDIRECT, SECONDARY, INCIDENTAL, OR CONSEQUENTIAL DAMAGES ARISING FROM OWNERSHIP OR USE OF THIS PRODUCT, INCLUDING INCONVENIENCE OR LOSS OF USE. THERE ARE NO WARRANTIES THAT EXTEND BEYOND THE FACE OF THIS DOCUMENT. NO AGENT OR REPRESENTATIVE OF WARMUP, INC. HAS ANY AUTHORITY TO EXTEND OR MODIFY THIS WARRANTY UNLESS SUCH EXTENSION OR MODIFICATION IS MADE IN WRITING BY A CORPORATE OFFICER.

DUE TO DIFFERENCES IN BUILDING AND FLOOR INSULATION, CLIMATE AND FLOOR COVERINGS, WARMUP, INC. MAKES NO REPRESENTATION THAT THE FLOOR TEMPERATURE WILL ACHIEVE ANY PARTICULAR TEMPERATURE OR TEMPERATURE RISE. UL STANDARD LISTING REQUIREMENTS LIMIT THE HEAT OUTPUT OF WARMUP UNDERTILE HEATING, AS SUCH, USERS MAY OR MAY NOT BE SATISFIED WITH THE FLOOR WARMTH THAT IS PRODUCED. WARMUP DOES WARRANT THAT ALL HEATERS WILL PRODUCE THE RATED WATT OUTPUT LISTED ON THE HEATER NAMEPLATE, WHEN OPERATED AT THE RATED VOLTAGE.

TERMS AND CONDITIONS

Shipping Discrepancies:

Incoming materials should be inventoried for completeness and for possible shipping damage. Any visible damages or shortages must be noted prior to accepting the material. Any discrepancy concerning type or quantity of material shipped, must be brought to the attention of your Warmup® reseller within 15 days of the shipping date entered on the packing slip for the order.

Miscellaneous:

The terms of this Limited Warranty are exclusive and supersede any other warranty or terms and conditions relating to the subject matter whether included in a purchase order for this product or in any other document or statement.



Buy at
International Flooring Center, Inc.
323-731-8453
www.FlooringSupplyShop.com

Register your Warmup warranty at
www.warmup.com or www.warmup.ca

Warmup Offices in North America:

USA: Warmup Inc | 52 Federal Road Unit 1F Danbury CT 06810
Tel 1-888-927-6333 | Fax 1-888-927-4721
E-mail us@warmup.com | Web www.warmup.com

CANADA: Warmup Inc | 4 Robert Speck Parkway, Suite 1500
Mississauga Ontario L4Z 1S1
Tel 905-990-2075 | Fax 905-366-7324
E-mail ca@warmup.com | Web www.warmup.ca