

# ACCESSORIES FOR SAW MACHINES

BRIDGE AND JOB SITE SAW MACHINES

**MADE IN ITALY**

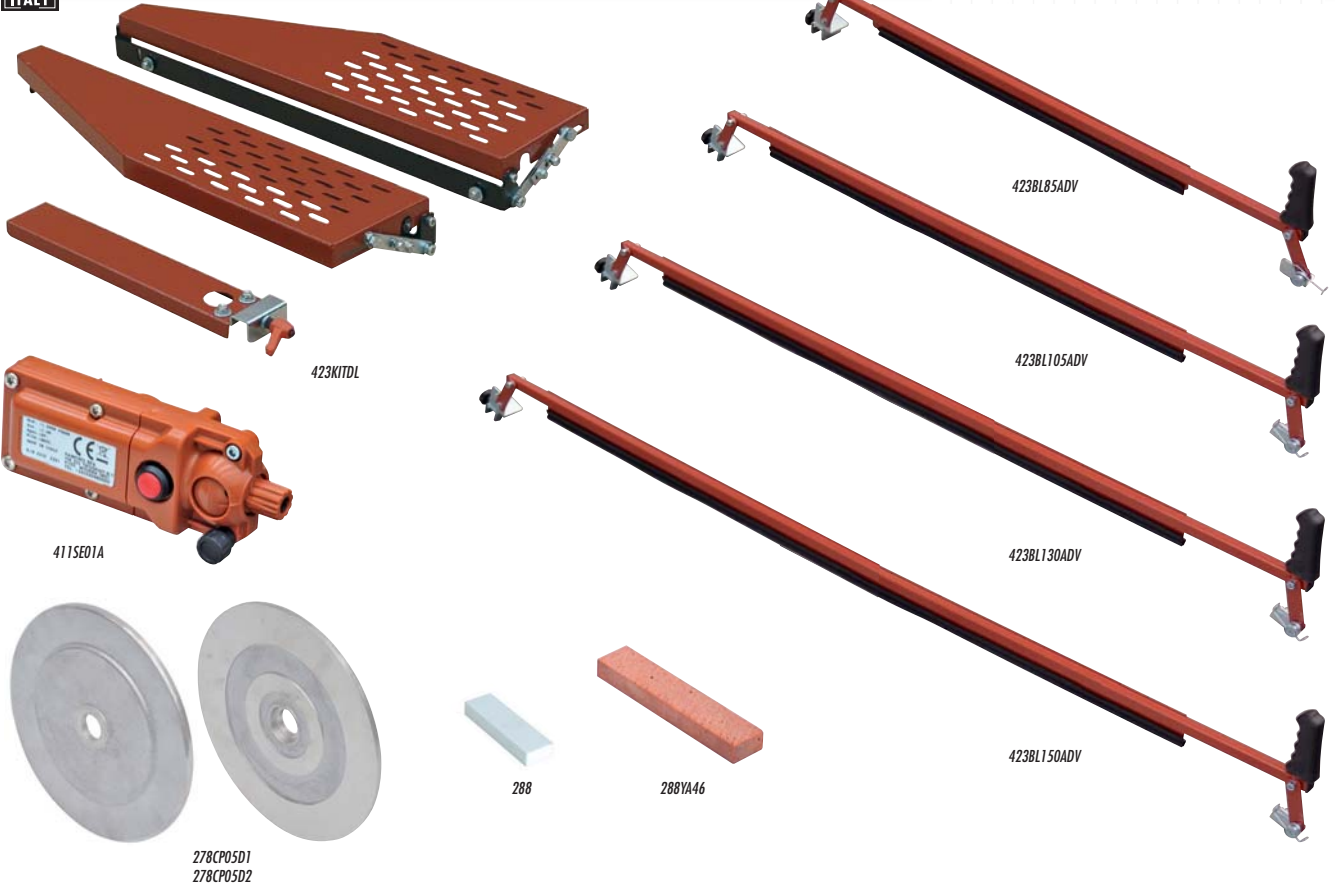

Part No.			Description				
<b>423KITDL</b>	8024648010476	1	Optional kit: folding extension tables and 90° left square	71x22x10 cm	28"x8 5/8"x4"	5 Kg	11 lbs
<b>424BL75</b>	8024648006622	1	Tile holder for Pikus 75	89x24x20 cm	35"x9 1/2"x7 7/8"	1,8 Kg	4 lbs
<b>423BL105ADV</b>	8024648056757	1	Tile holder for Pikus 105 ADV, SMS 100, Zoe 105 ADV	117x24x20 cm	46"x9 1/2"x7 7/8"	2,6 Kg	5.7 lbs
<b>423BL130ADV</b>	8024648066459	1	Tile holder for Pikus 130 ADV, SMS 125, Zoe 130 ADV	153x24x20 cm	60"x9 1/2"x7 7/8"	3 Kg	6.6 lbs
<b>423BL150ADV</b>	8024648071187	1	Tile holder for SMS150 and Zoe 150 ADV	178x24x20 cm	70"x9 1/2"x7 7/8"	3,5 Kg	7.7 lbs
<b>411SE01A</b>	8024648065254	1	Laser without stirrup	-	-	-	-
<b>411SE A1</b>	8024648070906	1	Laser with stirrup for ZOE Adv	-	-	-	-
<b>411SE A2</b>	8024648070913	1	Laser with stirrup for Pikus Adv	-	-	-	-
<b>411SE A4</b>	8024648070937	1	Laser with stirrup for SMS100,125 and 150	-	-	-	-
<b>411SE A9</b>	8024648005663	1	Laser with stirrup for SMS220 and SMS260	-	-	-	-
<b>288</b>	8024648004178	1	Dressing stone 30 x100xh 15 mm (1 3/16"x 4"xh 5/8")	-	-	-	-
<b>288YA46</b>	8024648079619	1	Dressing stone 45x230xh 25 mm (1 3/4"x9 1/16"xh 1")	-	-	-	-
<b>278CP05D1</b>	8024648079060	2	Flanges (pair) Ø 200 mm (8") for Zoe ADV	-	-	-	-
<b>278CP05D2</b>	8024648079077	2	Flanges (pair) Ø 200 mm (8") for SMS and Mistral	-	-	-	-

Part No.	EXPLOIT			BOLT			MISTRAL			PIKUS				PIKUS ADV						SMS						ZOE ADV				SA	SA	SHERPA
	70	90	120	90	120	150	90	120	150	75	85	105	130	100	125	150	220	260	85	105	130	150	80	09								
<b>423KITDL</b>	-	-	-	-	-	-	-	-	-	-	•	•	•	•	•	•	•	•	•	•	•	•	-	-	-							
<b>424BL75</b>	-	-	-	-	-	-	-	-	-	-	•	-	-	-	-	-	-	-	-	-	-	-	-	-	-							
<b>423BL105ADV</b>	-	-	-	-	-	-	-	-	-	-	-	•	-	-	-	-	-	-	-	•	•	•	•	-	-							
<b>423BL130ADV</b>	-	-	-	-	-	-	-	-	-	-	-	-	•	-	-	-	-	-	-	-	•	•	-	-	-							
<b>423BL150ADV</b>	-	-	-	-	-	-	-	-	-	-	-	-	-	•	-	-	-	-	-	-	-	•	•	-	-							
<b>411SE01A</b>	-	-	-	-	-	-	-	-	-	-	-	-	-	-	-	-	-	-	-	-	-	-	-	-	-							
<b>411SE A1</b>	-	-	-	-	-	-	-	-	-	-	-	•	•	•	•	•	•	•	•	•	•	•	•	-	-							
<b>411SE A2</b>	-	-	-	-	-	-	-	-	-	-	-	•	•	•	•	•	•	•	•	•	•	•	•	-	-							
<b>411SE A4</b>	-	-	-	-	-	-	-	-	-	-	-	-	-	•	•	•	•	•	•	•	•	•	•	-	-							
<b>411SE A9</b>	-	-	-	-	-	-	-	-	-	-	-	-	-	-	-	-	-	-	-	-	-	-	•	•	-							
<b>288</b>	•	•	•	•	•	•	•	•	•	•	•	•	•	•	•	•	•	•	•	•	•	•	•	•	•							
<b>288YA46</b>	•	•	•	•	•	•	•	•	•	•	•	•	•	•	•	•	•	•	•	•	•	•	•	•	•							
<b>278CP05D1</b>	-	-	-	-	-	-	-	-	-	-	-	-	-	-	-	-	-	-	-	-	•	•	•	•	-							
<b>278CP05D2</b>	-	-	-	-	-	-	-	•	•	•	-	-	-	-	-	-	-	-	-	-	-	-	-	-	-							







**SIDE BENCH WITH ADJUSTABLE SQUARE AND WATER CONTAINMENT BARS FOR PIKUS, ZOE E SMS**

MADE IN ITALY



- The side bench with adjustable square allow to have a perfect parallelism between the tile edge and the cutting line: this is extremely useful while performing either jolly/ 45° cut or 90° straight cut. Thanks to this accessory wet saws Pikus, Zoe and SMS become suitable for cutting jolly/45° on slabs having significant overall length (up to 200 cm).
- The two water containment bars with nylon brushes allows to reduce any leakage during the cut, making sure all water goes into machine tank.

Part No.	Barcode	Box	Description	Box	Weight
374BSQ 130	8024648099068	1	Side bench with adjustable square for Pikus 130 Adv, SMS 125 and Zoe 130 Adv	-	-
374BSQ 150	8024648099075	1	Side bench with adjustable square for SMS 150 and Zoe 150 Adv	-	-
374BSQ 220	8024648099082	1	Side bench with adjustable square for SMS 220	-	-
374BSQ 260	8050532001718	1	Side bench with adjustable square for SMS 260	-	-
263PE04A085	8024648019585	1	Water containment bars with nylon brushes for Pikus 85 Adv and Zoe 85 Adv – pair	120xØ 12,5 cm	47 1/4"xØ 5" 3,6 Kg 7.9 lbs
263PE04A105	8024648019592	1	Water containment bars with nylon brushes for Pikus 105 Adv, SMS 100 and Zoe 105 Adv – pair	120xØ 12,5 cm	47 1/4"xØ 5" 3,8 Kg 8.4 lbs
263PE04A130	8024648022233	1	Water containment bars with nylon brushes for Pikus 130 Adv, SMS 125 and Zoe 130 Adv – pair	165xØ 12,5 cm	65"xØ 5" 4,6 Kg 10.1 lbs
263PE04A150	8024648022851	1	Water containment bars with nylon brushes for SMS 150 and Zoe 150 Adv – pair	165xØ 12,5 cm	65"xØ 5" 4,9 Kg 10.8 lbs
263PE04A200	8024648026507	1	Water containment bars with nylon brushes for SMS 220 – pair	200xØ 12,5 cm	79"xØ 5" 6,6 Kg 14.6 lbs
263PE04A260	8050532001824	1	Water containment bars with nylon brushes for SMS 260 – pair	250xØ 12,5 cm	8 1/2"xØ 5" 6,9 Kg 15.2 lbs

Part No.	EXPLOIT			BOLT			MISTRAL			PIKUS				PIKUS ADV				SMS				ZOE ADV				SA 80	SA 09	SHERPA
	70	90	120	90	120	150	90	120	150	75	85	105	130	100	125	150	220	260	85	105	130	150	-	-	-			
374BSQ 130	-	-	-	-	-	-	-	-	-	-	-	-	•	-	•	-	-	-	-	-	-	•	-	-	-	-	-	
374BSQ 150	-	-	-	-	-	-	-	-	-	-	-	-	-	-	-	•	-	-	-	-	-	-	•	-	-	-	-	
374BSQ 220	-	-	-	-	-	-	-	-	-	-	-	-	-	-	-	-	•	-	-	-	-	-	-	-	-	-	-	
374BSQ 260	-	-	-	-	-	-	-	-	-	-	-	-	-	-	-	-	-	•	-	-	-	-	-	-	-	-	-	
263PE04A085	-	-	-	-	-	-	-	-	-	-	-	-	-	-	-	-	-	-	-	•	-	-	-	-	-	-	-	
263PE04A105	-	-	-	-	-	-	-	-	-	-	-	-	-	-	-	-	-	-	-	-	•	-	-	-	-	-	-	
263PE04A130	-	-	-	-	-	-	-	-	-	-	-	-	-	-	-	-	-	-	-	-	-	•	-	-	-	-	-	
263PE04A150	-	-	-	-	-	-	-	-	-	-	-	-	-	-	-	-	-	-	-	-	-	-	•	-	-	-	-	
263PE04A200	-	-	-	-	-	-	-	-	-	-	-	-	-	-	-	-	-	-	-	-	-	-	-	•	-	-	-	
263PE04A260	-	-	-	-	-	-	-	-	-	-	-	-	-	-	-	-	-	-	-	-	-	-	-	-	•	-	-	





MADE IN ITALY

BRIDGE AND JOB SITE SAW MACHINES

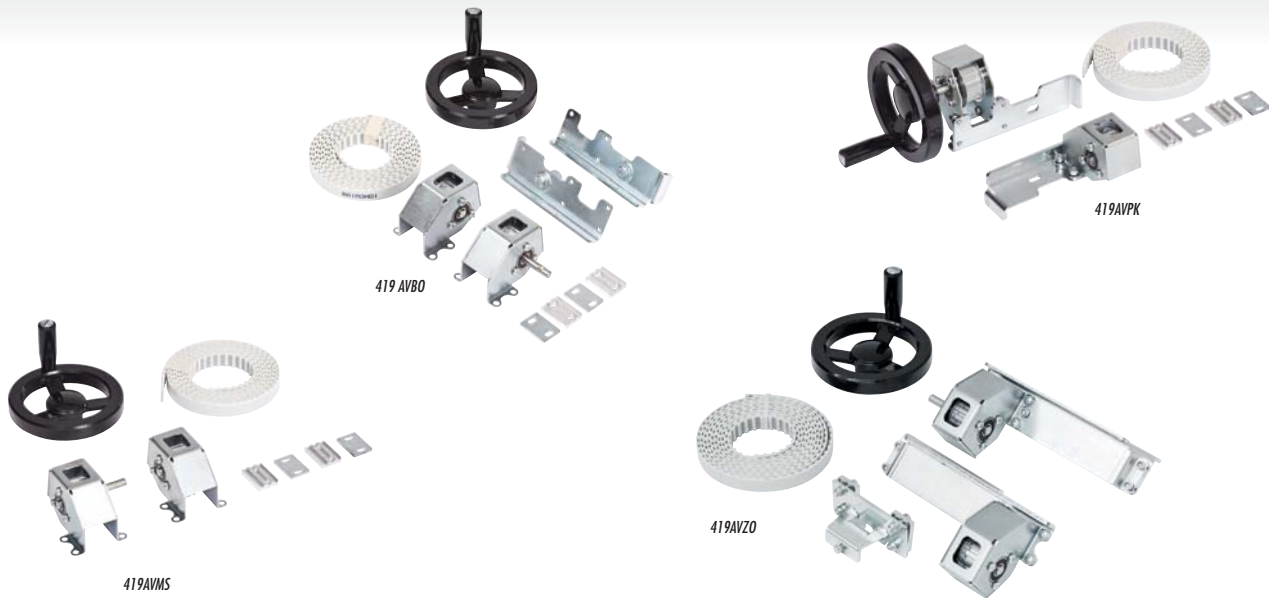

Part No.			Description
419AVBO=120	8024648090331	1	Wheel kit feed for Bolt 120
419AVBO=150	8024648090348	1	Wheel kit feed for Bolt 150
419AVMS=120	8024648090355	1	Wheel kit feed for Mistral 120/SMS 125
419AVMS=150	8024648090362	1	Wheel kit feed for Mistral 150
419AVMS=155	8024648022714	1	Wheel kit feed for SMS 150
419AVPK 085	8024648091543	1	Wheel kit feed for Pikus 85 Adv
419AVPK 105	8024648091550	1	Wheel kit feed for Pikus 105 Adv
419AVPK 130	8024648092755	1	Wheel kit feed for Pikus 130 Adv
419AVZO 085	8024648093233	1	Wheel kit feed for Zoe 85 Adv
419AVZO 105	8024648093240	1	Wheel kit feed for Zoe 105 Adv
419AVZO 130	8024648093257	1	Wheel kit feed for Zoe 130 Adv
419AVZO 150	8024648093264	1	Wheel kit feed for Zoe 150 Adv

Part No.	EXPLOIT			BOLT		MISTRAL			PIKUS			PIKUS ADV			SMS					ZOE ADV				SA	SA	SHERPA
	70	90	120	90	120	150	90	120	150	75	85	105	130	100	125	150	220	260	85	105	130	150	80	09		
419AVBO=120	-	-	-	-	•	-	-	-	-	-	-	-	-	-	-	-	-	-	-	-	-	-	-	-	-	
419AVBO=150	-	-	-	-	-	•	-	-	-	-	-	-	-	-	-	-	-	-	-	-	-	-	-	-	-	
419AVMS=120	-	-	-	-	-	-	•	-	-	-	-	-	-	-	•	-	-	-	-	-	-	-	-	-	-	
419AVMS=150	-	-	-	-	-	-	-	•	-	-	-	-	-	-	-	-	-	-	-	-	-	-	-	-	-	
419AVMS=155	-	-	-	-	-	-	-	-	-	•	-	-	-	-	-	•	-	-	-	-	-	-	-	-	-	
419AVPK 085	-	-	-	-	-	-	-	-	-	-	•	-	-	-	-	-	-	-	-	-	-	-	-	-	-	
419AVPK 105	-	-	-	-	-	-	-	-	-	-	-	•	-	-	-	-	-	-	-	-	-	-	-	-	-	
419AVPK 10	-	-	-	-	-	-	-	-	-	-	-	-	-	-	-	-	-	-	-	-	-	-	-	-	-	
419AVZO 085	-	-	-	-	-	-	-	-	-	-	-	-	-	-	-	-	-	-	-	•	-	-	-	-	-	
419AVZO 105	-	-	-	-	-	-	-	-	-	-	-	-	-	-	-	-	-	-	-	-	•	-	-	-	-	
419AVZO 130	-	-	-	-	-	-	-	-	-	-	-	-	-	-	-	-	-	-	-	-	-	•	-	-	-	
419AVZO 150	-	-	-	-	-	-	-	-	-	-	-	-	-	-	-	-	-	-	-	-	-	-	•	-	-	





BRIDGE AND JOB SITE SAW MACHINES

**ACCESSORIES FOR TROLLEY MACHINES**

**MADE IN ITALY**



192SQ24A

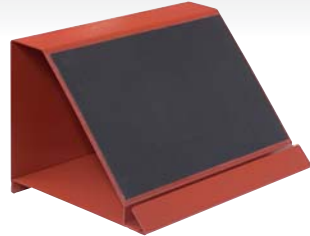

218DJ



156CP01A



191CL05A



288



288YA46



154SE17CP



411SE01A

Part No.			Description				
192SQ24A	8024648005656	1	Adjustable square 0°/45°/90° for SA80, SA09, SHERPA	40x17xh 8 cm	16"x6 3/4"xh 3 1/8"	1,5 Kg	3.3 lbs
156CP01A	8024648054272	1	Extension side tables for SA80	40x40xh 15 cm	15 3/4"x15 3/4"xh 6"	4,1 Kg	9.0 lbs
218DJ	8024648009777	1	Jolly device for SA09	71x23xh 11cm	28"x9"xh 4"	4,4 Kg	9.7 lbs
154SE17CP	8024648066480	1	Handles for SA09	40x28xh 18 cm	15 3/4"x11"xh 7"	6 Kg	13 lbs
191CL05A	8024648058003	1	Side square for SA80	68x66xh 10cm	27"x26"xh 4"	4,5 Kg	9.9 lbs
411SE01A	8024648065254	1	Laser without stirrup	-	-	-	-
411SE A4	8024648070937	1	Laser with stirrup for SMS and SA80	-	-	-	-
411SE A3	8024648070920	1	Laser with stirrup for Sherpa	-	-	-	-
411SE A8	8024648070975	1	Laser with stirrup for SA09	-	-	-	-
288	8024648004178	1	Dressing stone 30 x100xh 15 mm (1 3/16"x 4"xh 5/8")	-	-	-	-
288YA46	8024648079619	1	Dressing stone 45x230xh 25 mm (1 3/4"x9 1/16"xh 1")	-	-	-	-

Part No.	EXPLOIT			BOLT			MISTRAL			PIKUS	PIKUS ADV			SMS					ZOE ADV				SA	SA	SHERPA
	70	90	120	90	120	150	90	120	150	75	85	105	130	100	125	150	220	260	85	105	130	150	80	09	
192SQ24A	-	-	-	-	-	-	-	-	-	-	-	-	-	-	-	-	-	-	-	-	-	-	•	•	•
156CP01A	-	-	-	-	-	-	-	-	-	-	-	-	-	-	-	-	-	-	-	-	-	-	•	-	-
218DJ	-	-	-	-	-	-	-	-	-	-	-	-	-	-	-	-	-	-	-	-	-	-	-	•	-
154SE17CP	-	-	-	-	-	-	-	-	-	-	-	-	-	-	-	-	-	-	-	-	-	-	•	•	•
191CL05A	-	-	-	-	-	-	-	-	-	•	•	•	•	•	•	•	•	•	•	•	•	•	•	-	-
411SE01A	-	-	-	-	-	-	-	-	-	-	-	-	-	-	-	-	-	-	-	-	-	-	-	-	-
411SE A4	-	-	-	-	-	-	-	-	-	-	-	-	-	•	•	•	-	-	-	-	-	-	•	-	-
411SE A3	-	-	-	-	-	-	-	-	-	-	-	-	-	-	-	-	-	-	-	-	-	-	-	-	•
411SE A8	-	-	-	-	-	-	-	-	-	-	-	-	-	-	-	-	-	-	-	-	-	-	-	•	-
288	•	•	•	•	•	•	•	•	•	•	•	•	•	•	•	•	•	•	•	•	•	•	•	•	•
288YA46	•	•	•	•	•	•	•	•	•	•	•	•	•	•	•	•	•	•	•	•	•	•	•	•	•

