

Snow/Ice Sensor 090

**Dimensions: 1-3/4" H x 3-7/16" OD
(45 mm H x 87 mm OD)**

The Snow/Ice Sensor 090 is an in ground sensor used with Watts Radiant snow melting controls 653 and 654, and some tekmar snow melting controls to automatically detect snow or ice on a driveway or walkway. The snow/ice sensor has 65 ft (20 m) of wire. This product can be used in applications ranging from residential driveways to commercial building fronts such as emergency access entries. This sensor allows the above snow melting controls to automatically operate the snow/ice melt system only when snow or ice is present, while also providing slab temperature feedback to the control.



Snow/Ice Sensor 090

Snow/Ice Sensor 090

DESCRIPTION	PROPERTY
Literature	ES-WR-Snow_Ice-090, IOM-WR-Snow_Ice-090-091
Packaged weight	4.4 lbs (2000g)
Dimensions	1-3/4" H x 3-7/16" OD (45 mm H x 87 mm OD)
Sensor material	Silicon brass, 65 ft. (20 m) 5 conductor stranded wire with polyethylene jacket
Approvals	CSA C US with Watts Radiant Snow Melting Controls 653 and 654
Operating Range	-30 to 170°F (-34 to 77°C)
Included	4 #4-40, 7/16" machined, stainless steel screws 4 #6-32, 3/8" flathead, slotted, stainless steel screws

Features

- Automatic snow/ice detection
- Slab temperature sensing
- Long wire included so in field splicing is not necessary
- Designed for long life in driveway and walkway installations
- 65 ft (20 m) of cable

Top View

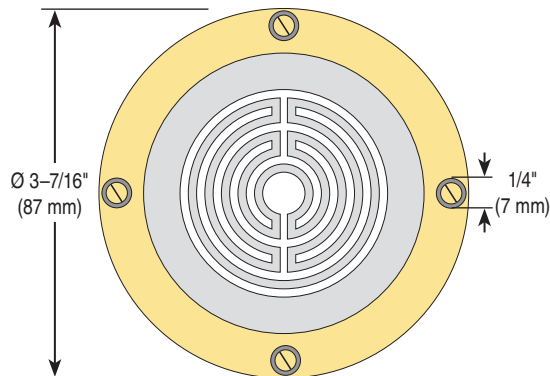

Side View

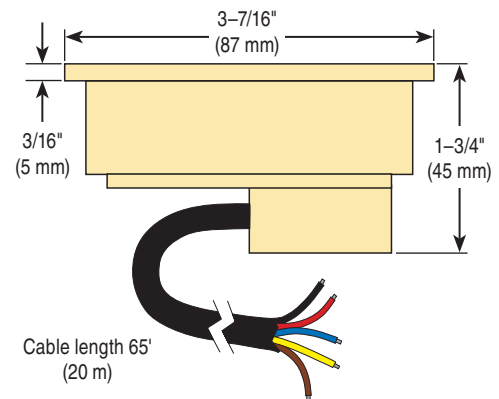

NOTICE

The Snow / Ice Sensor 090 must be operated by a Watts Radiant Snow Melting Control 653 or 654, or a compatible tekmar Snow Melting Control.

Product Options

Qty	Description	Model#	Order#
	Snow/Ice Sensor 090	300108	81005661

WattsRadiant™ Watts Radiant product specifications in U.S. customary units and metric are approximate and are provided for reference only. For precise measurements, please contact Watts Radiant Technical Service. Watts Radiant reserves the right to change or modify product design, construction, specifications, or materials without prior notice and without incurring any obligation to make such changes and modifications on Watts Radiant products previously or subsequently sold.

A Watts Water Technologies Company

USA: Springfield, MO • Tel. (800) 276-2419 • Fax: (417) 864-8161 • www.wattsradiant.com
Canada: Burlington, ONT. • Tel. (905) 332-4090 • Fax: (905) 332-7068 • www.watts.ca